

THIS DRAWING IS UNPUBLISHED. RELEASED FOR PUBLICATION 2011
 © COPYRIGHT 2011 TE CONNECTIVITY ALL RIGHTS RESERVED.

LOC	DIST	REVISIONS			
P	LTR	DESCRIPTION	DATE	DWN	APVD
B	-				
E		ECR-11-018847	13/09/11	JB	MG
F		ECR-11-019441	22/09/11	JB	MG
G		ECR-13-005845	04/04/13	MG	DP

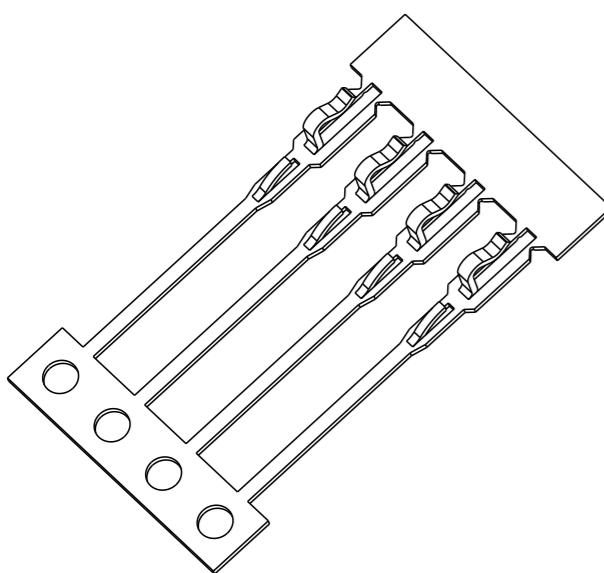

NOTE
 BOWING: AFTER UPPER TIE BAR REMOVAL- 1.5mm MAX. FOR 500mm
 PITCH: AFTER UPPER TIE BAR REMOVAL- 2.54±0.127

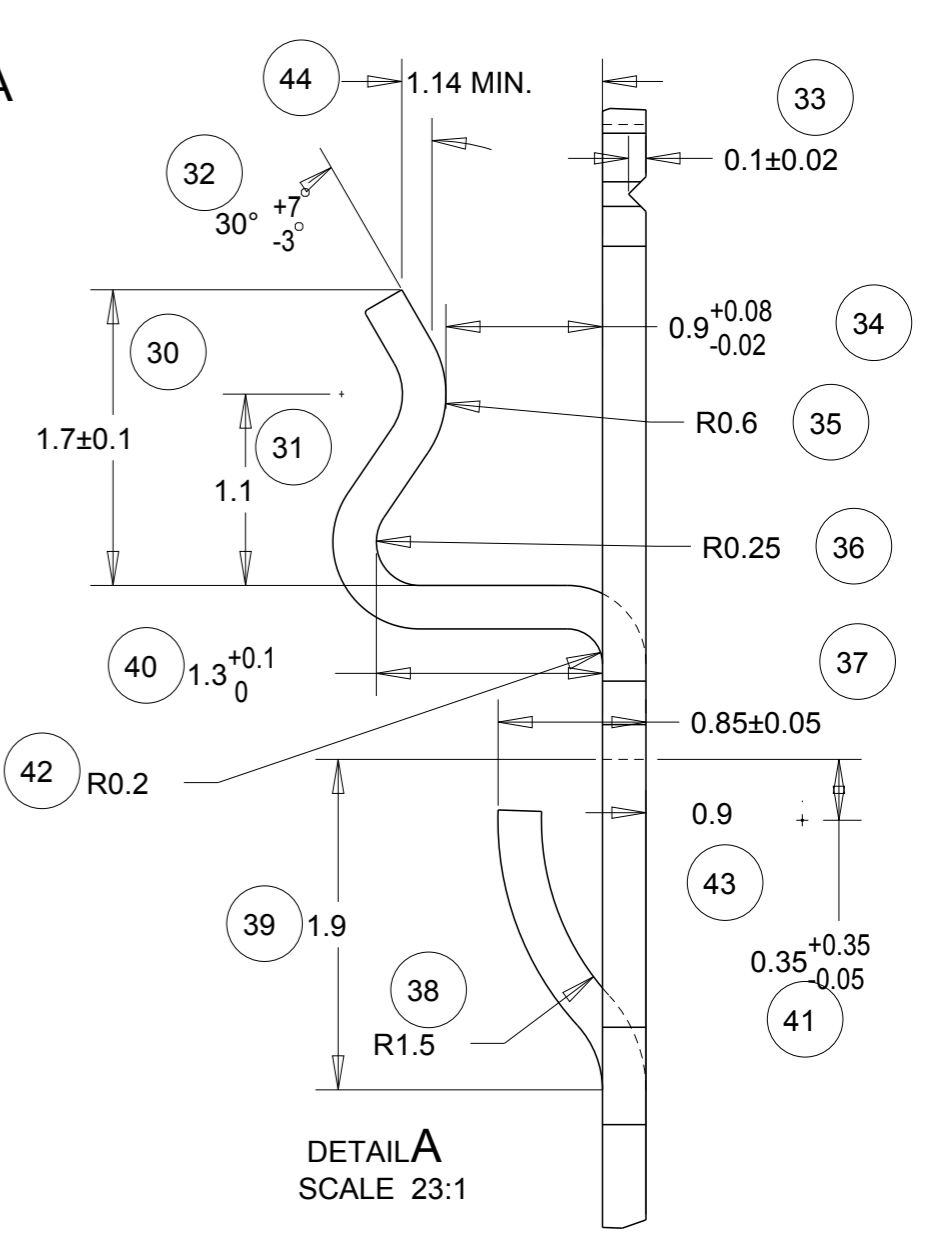
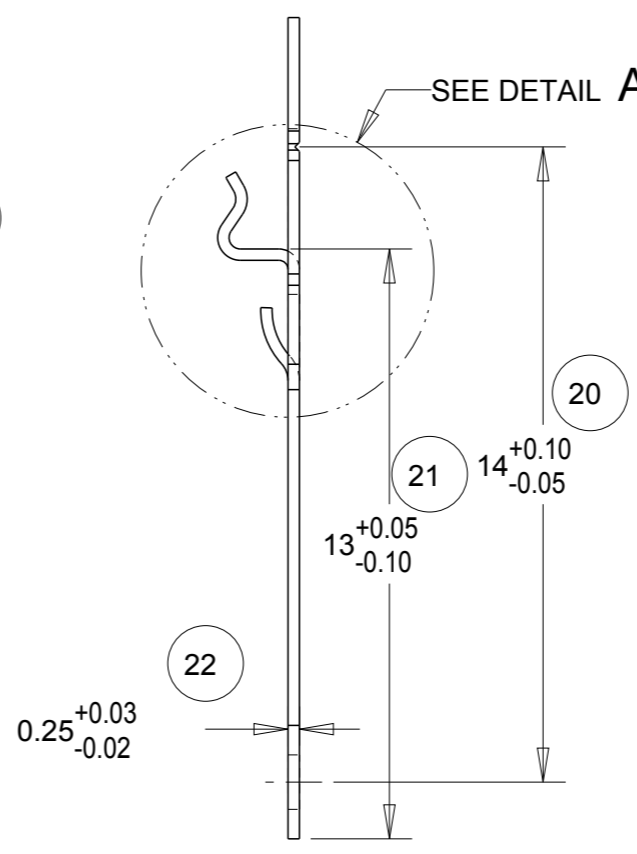
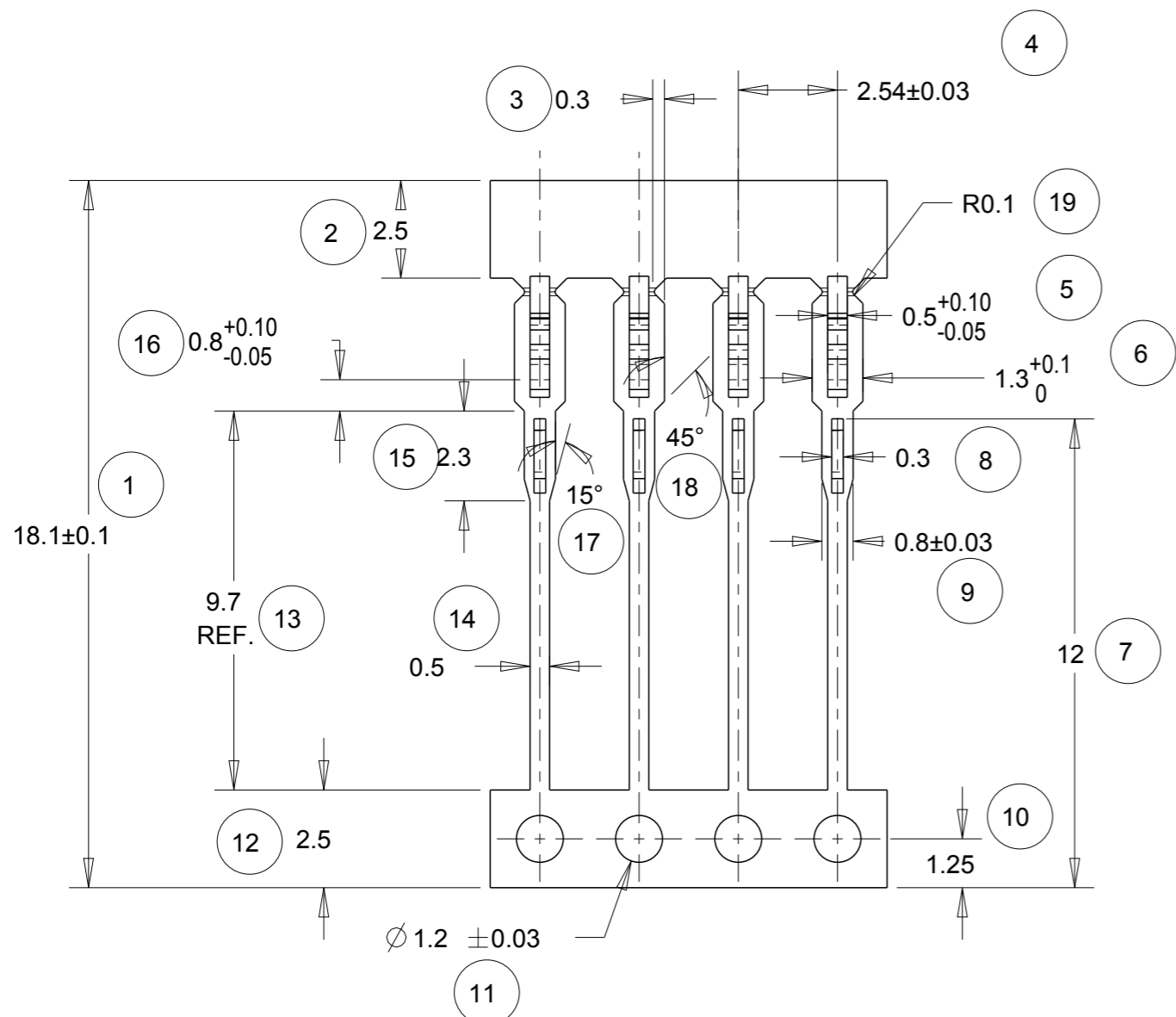
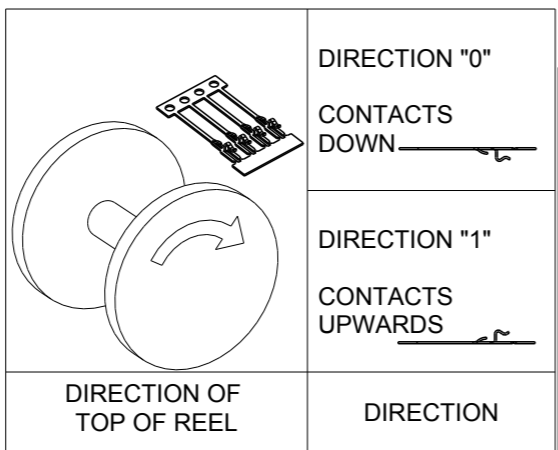

THIS DRAWING IS A CONTROLLED DOCUMENT.

DIMENSIONS:	TOLERANCES UNLESS OTHERWISE SPECIFIED:
mm	
0 PLC	±-
1 PLC	±-
2 PLC	±0.05
3 PLC	±-
4 PLC	±-
ANGLES	±0.5
MATERIAL	SEE ABOVE.
FINISH	-

DWN	J.BRIGHT	22/08/11
CHK	M.GREENER	22/08/11
APVD	D.PENNINGTON	22/08/11
PRODUCT SPEC	-	-
APPLICATION SPEC	-	-
WEIGHT	-	-

0	Sn over Ni	1544282-2
0	Sn	1544282-1
REELING	FINISH	PART NUMBER
STE TE Connectivity		
NAME SIL CONTACT		
SIZE	CAGE CODE	DRAWING NO
A3	00779	C-1544282
Customer Drawing	SCALE NTS	SHEET 1 OF 1 REV G